

*Hydraulic
press brakes*

EASY-FORM[®] SERIES

THE ULTIMATE BENDING MACHINE

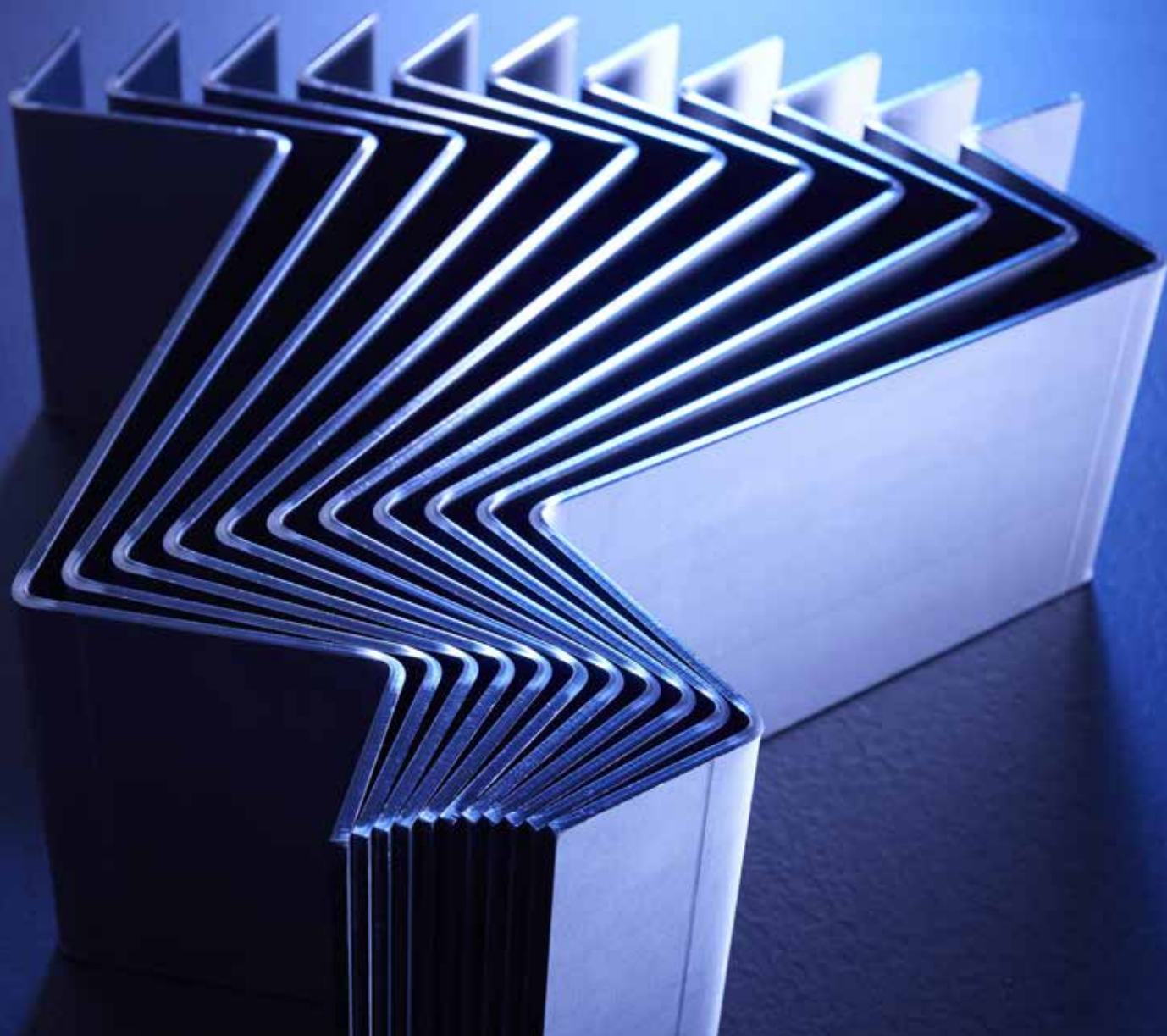

EASY-FORM® SERIES

THE ULTIMATE BENDING MACHINE

The Easy-Form® Series are smart, highly accurate bending machines through the integration of advanced technology and software.



STATUS LIGHTING

LED lights indicate the machine status.



INTUITIVE CONTROL

The 19" TOUCH-B control is user-friendly and makes full use of the machine's bending capabilities.



SERVO-CONTROLLED HYDRAULIC SYSTEM

The hydraulic components are machined in-house to a high standard from a solid steel billet.

The hardened steel pistons are precisely finished and micropolished for a lifetime of trouble-free service.



RIGID FRAME DESIGN

Easy-Form® models up to 400 ton/4m have a one-piece welded frame that can be installed at floor level. Longer bed lengths and higher pressing forces may require modified floor arrangements.





LED WORK ZONE LIGHTING SYSTEM

The backgauge and front work zone areas are illuminated for improved visibility.



EASY-FORM® LASER ADAPTIVE BENDING

LVD's patented in-process angle monitoring system adapts in real-time the ram/punch position to ensure precise, consistent bending.



CNC CROWNING

The Easy-Form press brake is equipped with an in-house developed and machined, tailor-made V-axis crowning system.

LINEAR ENCODERS

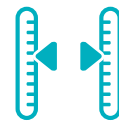

Bed-referenced linear encoders ensure precise control of the upper beam position and repeatability.



BACKGAUGE

The 2-, 5- or 6-axis backgauge is automatically positioned for optimum bending results.



ACCURATE BENDING

LINEAR ENCODERS

Referenced encoders are connected to the bed in such a way that deformation during bending does not influence the positioning accuracy of the ram (Y1, Y2).

.....

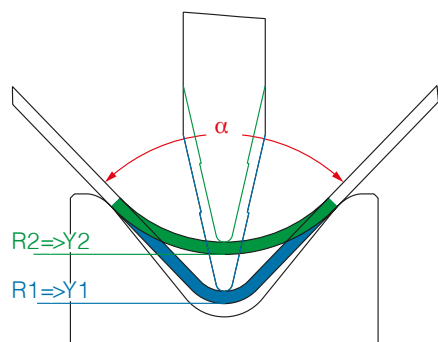

Fig. a

EASY-FORM® LASER (EFL) ADAPTIVE BENDING SYSTEM

EFL guarantees the desired angle from the first bending operation. The angle measuring system consists of two laser scanners located on the front and back of the table.

The unique aspect of EFL is that it uses V-die reference instead of sheet reference. EFL rapidly measures up to 100 samples per second between the die and the sheet. The scanners are linked to the CADMAN database containing a tooling library and proven bending results.

As the bending sequence of the press brake is initiated, the EFL system transmits the digital information in real time to the CNC control unit, which processes it and immediately adjusts the position of the ram/punch to achieve the correct angle. The bending process is not interrupted, and no production time is lost.

The unique design of the Easy-Form® Laser system allows the machine to adapt to material variations such as sheet thickness, strain hardening and grain direction, automatically compensating for any changes (Fig. a).



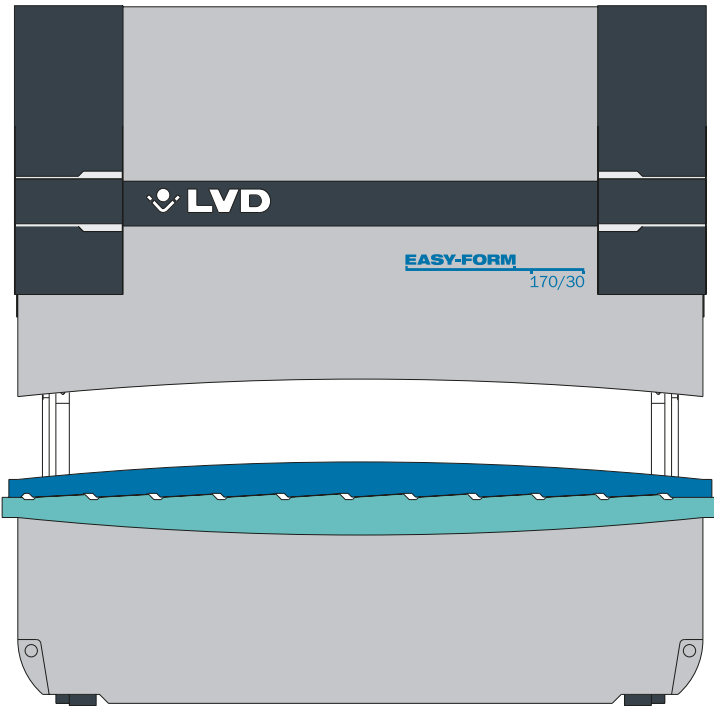
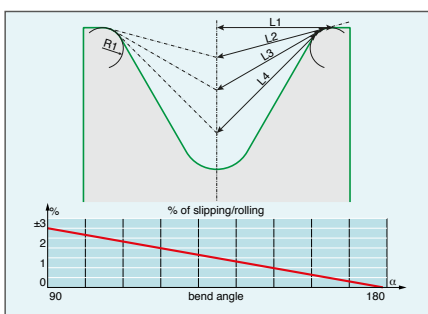

Fig. b

CNC CROWNING

Sheet thickness, bend length, die opening and tensile strength data are entered into the TOUCH-B control to determine the amount of crowning required to compensate for bed and ram deflection. LVD's proprietary design creates a perfect curve by using accurately machined contact wedges (Fig. b) that are moved against each other under servo control.

The crowning device is tailor-made for each individual machine. The associated components are machined and finished following the geometrical measurement between the ram and lower frame.



Normal radius

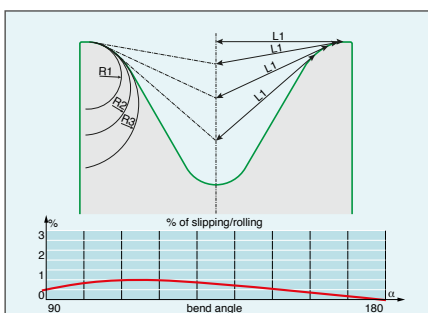

STONE radius

Fig. c

STONE RADIUS

All LVD dies feature a progressive STONE radius on both sides of the V opening, that reduces friction between the material and the die to minimise part marking (Fig. c).

STONE tooling also provides:

- reduced tool wear
- tool interchangeability
- reduced residue on stainless steel
- improved material control
- reduced tonnage requirements
- symmetric bending, even on longer parts

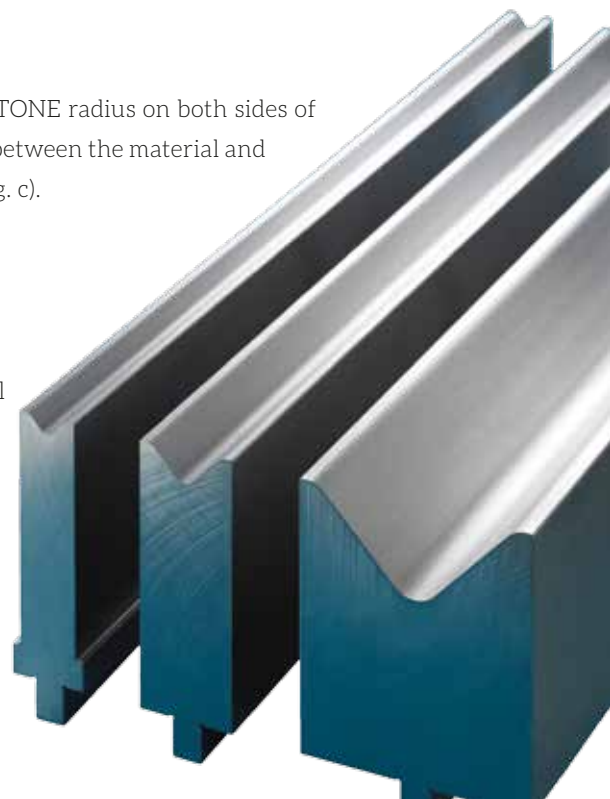

BACKGAUGE VERSATILITY

The backgauge ensures correct positioning of the workpiece in the machine, reducing overall cycle time and increasing productivity. LVD's backgauge systems offer the ultimate in flexibility in the production of both parallel and non-parallel flanges. The three-point gauge fingers allow automatic calculation and setting of both the backgauge and side stop positions for accurate part production.

Programming with LVD's CADMAN® software enables feasibility checks prior to production. The database information is automatically used to achieve precise flange lengths the first time. You can determine the exact position of the backgauge, no modifications are necessary throughout production. The range starts from a basic two-axis backgauge up to a full multiaxis system:

Standard two-axis backgauge (X, R) with manual Z-axis on Easy-Form 6

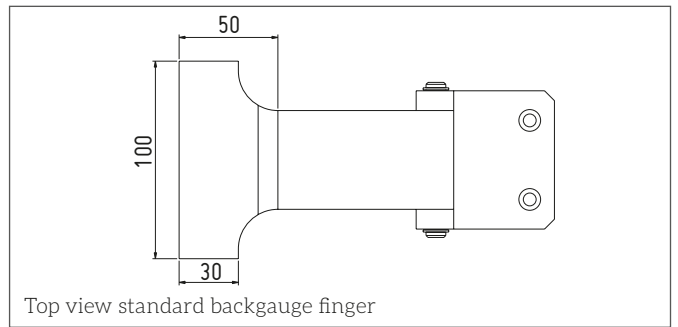

Five-axis backgauge (X, R, Z1, Z2, X') on Easy-Form 9

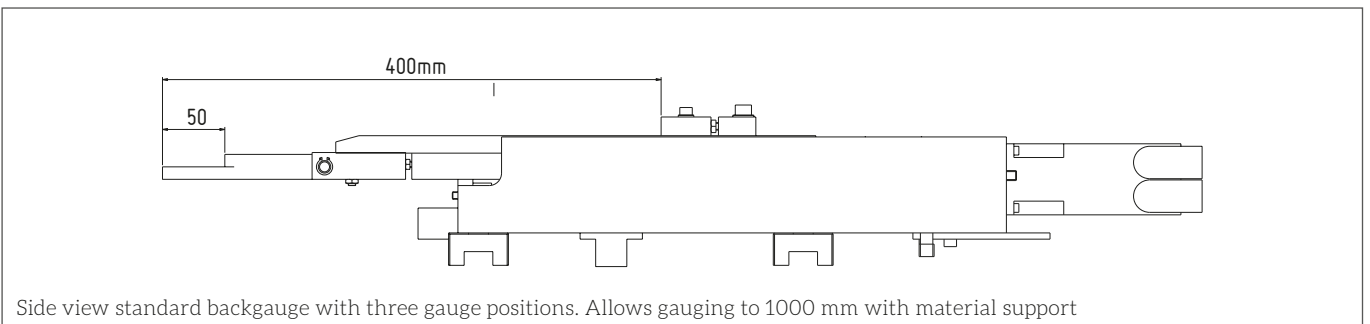
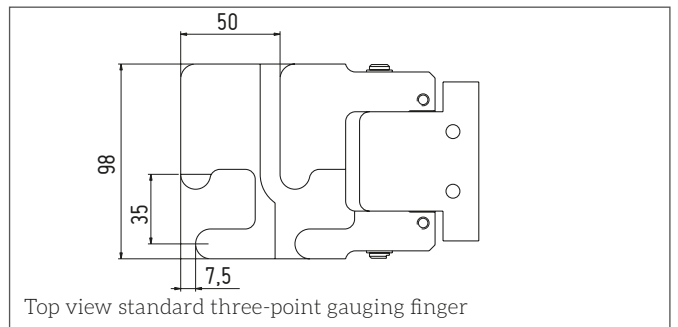

Six-axis modular backgauge (X1, R1, Z1, X2, R2, Z2) up to 400T on Easy-Form 9 (option)

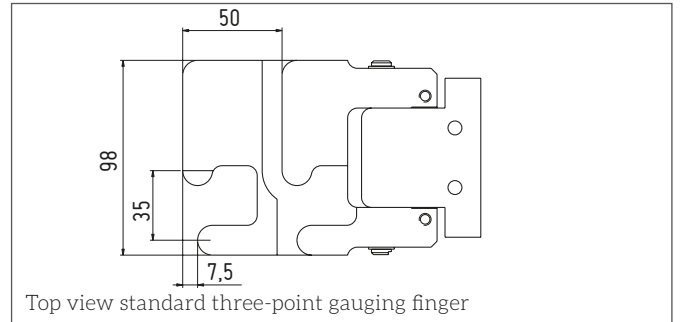

Six-axis back modular backgauge (X1, R1, Z1, X2, R2, Z2) for 500T and 640T

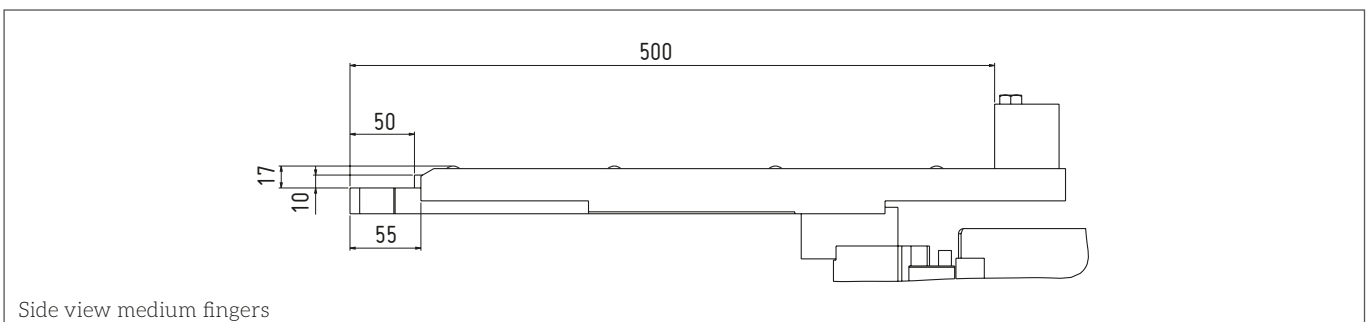
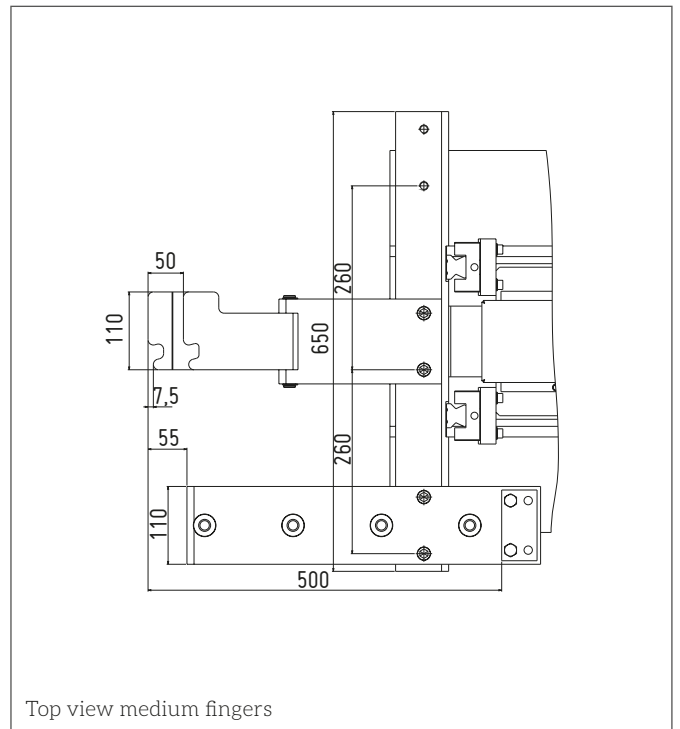

CONFIGURE YOUR PRESS BRAKE

Front and back led work zone lighting, a second foot pedal, a barcode reader to automatically load bending programs and an electrical cabinet air conditioner are included in the standard Easy-Form machine.

Maximising machine efficiency is the turbo hydraulic drive, a standard feature. This exclusive pump design regulates the flow rate to achieve optimal machine speed, avoiding unnecessary oil heating and energy waste. No energy is lost when the machine is holding the ram in position under pressure or when operating at low capacity.

Numerous options are available to increase output on your press brake: quick-acting hydraulic clamping on ram and on table, hardened clamping, increased distance table-ram/stroke of the ram, increased gap, laser safety of the bending line, interface for robot connection, and more.



Front supports on guide rails allow quick positioning along the entire length



Two programmable sheet followers

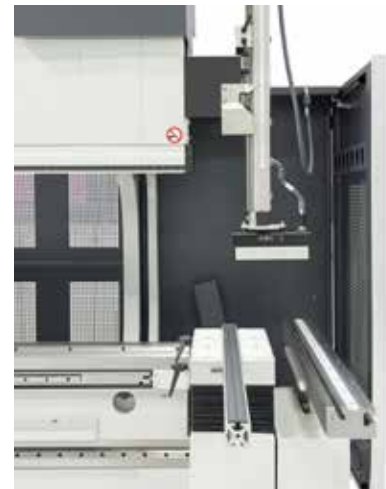

A parking zone is standard left/right.



Increase the table-ram/stroke/gap distance in 100 mm steps



Additional backgauge finger for gauging long parts



Backgauge finger with electric contact for robotic bending

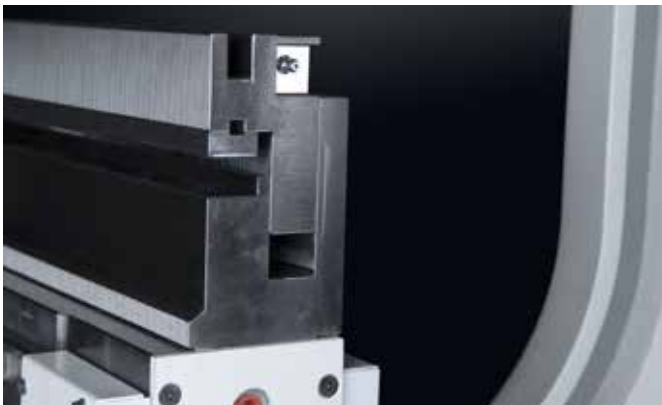

A hemming table for forming safety edges



Lasersafe safety system



Tandem operation: synchronised operation of two machines with a single master CNC control or independent operation of each machine with separate control, available with dissimilar tonnage and lengths in tandem configuration.

TECHNICAL SPECIFICATIONS

Type		80/15	80/20	80/25	110/30	110/40	110/42	135/30	135/40	135/42
Pressing force	kN	800	800	800	1.100	1.100	1.100	1.350	1.350	1.350
Pressure	bar	290	290	290	245	245	245	290	290	290
Working length	A mm	1.500	2.000	2.500	3.050	4.000	4.270	3.050	4.000	4.270
Dist. betw. uprights	B mm	1.050	1.550	2.050	2.600	3.150	3.820	2.600	3.150	3.820
Stroke	C mm	200	200	200	200	200	200	200	200	200
Distance table/ram	E mm	400	400	400	400	400	400	400	400	400
Gap	D mm	400	400	400	400	400	400	400	400	400
Table width	F mm	120	120	120	120	120	120	120	120	120
Max. load table	kN/m	2.000	2.000	2.000	2.000	2.000	2.000	2.000	2.000	2.000
Working height	mm	970	970	970	970	970	970	970	970	970
Approach speed*	mm/s	160	160	160	180	180	180	180	180	180
Working speed**	mm/s	22	22	22	22	22	22	22	22	22
Return speed	mm/s	200	200	200	200	200	200	200	200	200
Motor	kW	15	15	15	22	22	22	22	22	22
Weight	kg	5.500	6.000	6.500	9.500	11.000	12.000	9.500	11.000	12.000
Oil tank	L	125	125	125	250	250	250	250	250	250

Type		170/30	170/40	170/42	170/51	220/30	220/30 Plus	220/40	220/40 Plus	220/42
Pressing force	kN	1.700	1.700	1.700	1.700	2.200	2.200	2.200	2.200	2.200
Pressure	bar	285	285	285	285	285	285	285	285	285
Working length	A mm	3.050	4.000	4.270	5.100	3.050	3.050	4.000	4.000	4.270
Dist. betw. uprights	B mm	2.600	3.150	3.820	4.550	2.600	2.600	3.150	3.150	3.820
Stroke	C mm	200	200	200	200	200	300	200	300	200
Distance table/ram	E mm	400	400	400	400	400	570	400	570	400
Gap	D mm	400	400	400	400	400	400	400	400	400
Table width	F mm	120	120	120	120	120	200	120	200	120
Max. load table	kN/m	2.000	2.000	2.000	2.000	2.000	2.500	2.000	2.500	2.000
Working height	mm	970	970	970	1.020	970	1.000	970	1.000	970
Approach speed*	mm/s	180	180	180	180	120	120	120	120	120
Working speed**	mm/s	22	22	22	22	21	21	21	21	21
Return speed	mm/s	200	200	200	200	200	200	200	200	200
Motor	kW	37	37	37	37	37	37	37	37	37
Weight	kg	11.000	13.000	14.500	19.500	12.500	13.000	15.000	15.500	16.500
Oil tank	L	350	350	350	350	350	350	350	350	350

* For CE-countries only if the machine is equipped with an optional safety system. ** For CE-countries working speed is limited to safety norm.
 Different combinations of stroke and daylight are available in our standard range by steps of +100 mm.
 Specifications subject to change without prior notice.

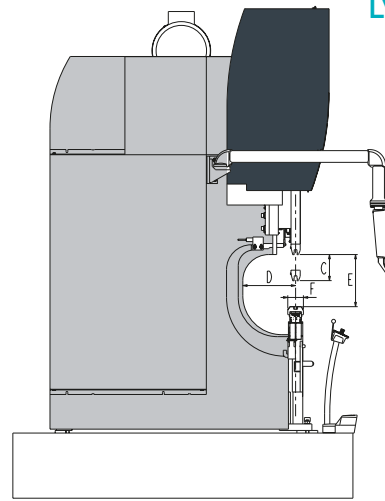
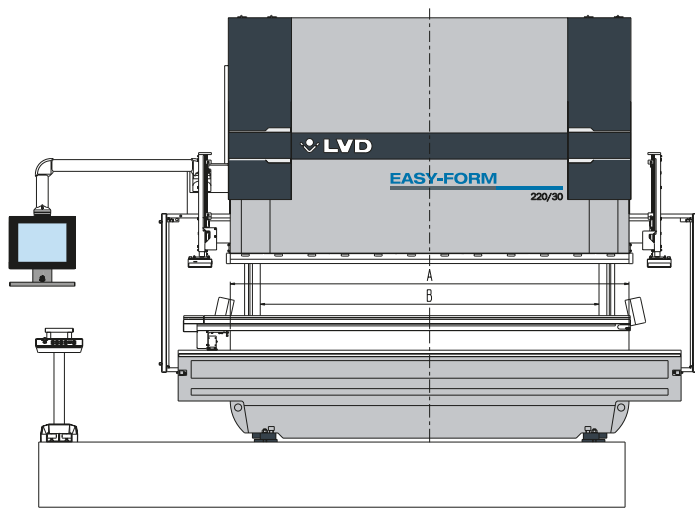

Type		220/42 Plus	220/51	220/51 Plus	220/61	220/61 Plus	320/30	320/40	320/45	320/51	320/61
Pressing force	kN	2.200	2.200	2.200	2.200	2.200	3.200	3.200	3.200	3.200	3.200
Pressure	bar	285	285	285	285	285	285	285	285	285	285
Working length	A mm	4.270	5.100	5.100	6.100	6.100	3.050	4.000	4.500	5.100	6.100
Dist. betw. uprights	B mm	3.820	4.550	4.550	5.050	5.050	2.600	3.150	3.820	4.270	5.050
Stroke	C mm	300	200	300	200	300	300	300	300	300	300
Distance table/ram	E mm	570	400	570	400	570	570	570	570	570	570
Gap	D mm	400	400	400	400	400	400	400	400	400	400
Table width	F mm	200	120	200	120	200	200	200	200	200	200
Max. load table	kN/m	2.500	2.000	2.500	2.000	2.500	2.500	2.500	2.500	2.500	2.500
Working height	mm	1.000	1.025	1.055	1.025	1.055	1.000	1.000	1.000	1.035	1.165
Approach speed*	mm/s	120	120	120	120	120	120	120	120	120	120
Working speed**	mm/s	21	21	21	21	21	14	14	14	14	14
Return speed	mm/s	200	200	200	200	200	130	130	130	130	130
Motor	kW	37	37	37	37	37	37	37	37	37	37
Weight	kg	17.000	20.500	21.000	23.500	24.000	21.000	23.000	25.500	29.000	36.000
Oil tank	L	350	350	350	350	350	400	400	400	400	400

Type		400/40	400/45	400/51	400/61	500/40	500/45	500/51	500/61	640/45	640/61	640/80
Pressing force	kN	4.000	4.000	4.000	4.000	5.000	5.000	5.000	5.000	6.400	6.400	6.400
Pressure	bar	290	290	290	290	290	290	290	290	290	290	290
Working length	A mm	4.000	4.500	5.100	6.100	4.000	4.500	5.100	6.100	4.500	6.100	8.000
Dist. betw. uprights	B mm	3.150	3.820	4.270	5.050	3.150	3.760	4.050	5.050	3.760	5.050	7.050
Stroke	C mm	300	300	300	300	300	300	300	300	300	300	300
Distance table/ram	E mm	570	570	570	570	570	570	570	570	570	570	570
Gap	D mm	400	400	400	400	400	400	400	400	400	400	400
Table width	F mm	200	200	200	200	200	200	200	200	200	200	200
Max. load table	kN/m	2.500	2.500	2.500	2.500	2.500	2.500	2.500	2.500	2.500	2.500	2.500
Working height	mm	970	970	970	970	970	970	970	970	970	970	970
Approach speed*	mm/s	100	100	100	100	100	100	100	100	90	90	90
Working speed**	mm/s	11	11	11	11	9	9	9	9	9	9	9
Return speed	mm/s	120	120	120	120	80	80	80	80	100	100	100
Motor	kW	37	37	37	37	37	37	37	37	55	55	55
Weight	kg	30.500	32.000	34.000	37.000	39.400	42.200	43.820	49.420	49.300	57.000	71.550
Oil tank	L	500	500	500	500	650	650	650	650	850	850	850

SOFTWARE INTEGRATION

LVD's database-driven CADMAN® suite software integrates sheet metalworking processes, production control, communication and management. It provides users real-time data to make informed choices, enabling optimised programming and maximised throughput in the workshop.

CADMAN-JOB

CADMAN-JOB connects the front office intakes and processing of orders with the shop floor operations. The software creates or imports production orders from an ERP system allowing users to generate production jobs for bending.



CADMAN-B

After importing a 3D CAD part, CADMAN-B automatically defines inclined, parallel and multi-bends, as well as hemming and preliminary bends. The module can visualize the complete bend process with start to finish collision detection, gauge positions and tool setups.

TOUCH-B control

The speed and simplicity of touch screen technology is combined with the power of a CNC control. TOUCH-B works with the centralized CADMAN database, is compatible with CADMAN-JOB and CADMAN-B and has access to LVD's customer support helpdesk.

TOUCH-i4

TOUCH-i4 is an industrial-grade Windows®-based tablet that provides an overview of the entire fabrication workshop. It collects real-time information from your LVD machine(s) powered by the centralized CADMAN database.

CADMAN-SDI

The Smart Drawing Importer allows fast CAD file import. CADMAN-SDI converts the file to OSM and stores it in the central datase. All cost drivers are displayed and can be exported for making an accurate cost estimate.

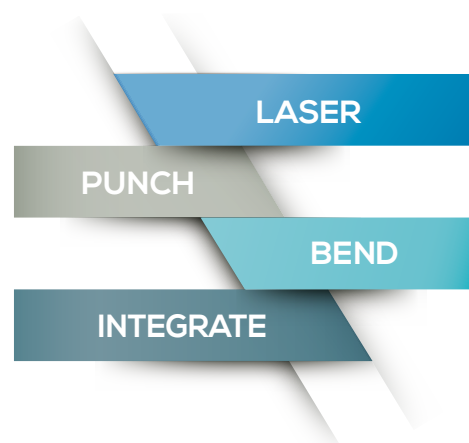

LVD Company nv, Nijverheidslaan 2, B-8560 GULLEGEM, BELGIUM
Tel. +32 56 43 05 11 - marketing@lvd.be - www.lvdgroup.com

For full address details of your local subsidiary or agent, please visit our website.

