

caratteristiche tecniche

technical data

Tavola di lavoro

Dimensione tavola	Working table	Table size	Ø 1000
Max. carico su tavola		<i>Max. allowed load on the table</i>	3000 kg
Cave a T		<i>T slots</i>	18x7 x 125 mm
Massimo volteggio pezzo		<i>Max allowed swing</i>	1450 mm
Massimo volume di lavoro		<i>Max work volume</i>	1000 x 1000 mm

Corse assi lineari

Corsa asse X	Linear axes strokes	X axis stroke	1250 mm
Corsa asse Y		Y axis stroke	1350 mm
Corsa asse Z		Z axis stroke	1200 mm
Rapido assi X - Y - Z		X - Y - Z axes rapid feed	50 m/min
Accelerazione		Acceleration	5 m/s²

Testa tiltante (asse A)

Corsa testa asse A	Tilting head (A axis)	A axis stroke	+/-105° Gradi / Degree
Rapido		Rapid feed	100 Giri/min / rpm
Divisione angolare minima		Min. rotating step	0.001 Gradi / Degree

Tavola girevole (asse C)

Divisione angolare minima	Rotary table (C axis)	Min. rotating step	0.001 Gradi / Degree
Rapido		Rapid feed	80 Giri/min / rpm
Coppia di lavoro		Working torque	2310 Nm
Capacità di bloccaggio		Clamping torque	4000 Nm

Dati elettromandrino

Attacco utensile	Electrospindle	Spindle taper	HSK 100
Velocità di rotazione		Spindle speed	15000 Giri/min / rpm
Potenza (40%)		Spindle power (S6)	45 kw
Coppia (40%)		Spindle torque (S6)	145 Nm

Magazzino utensili

Numero posizioni	Automatic tool changer	Tool positions	30
Diam. max. utensile posti tutti occupati		Max. tool diameter (full pockets)	90 mm
Diam. max. utensile posti adiacenti liberi		Max. tool diameter (adjacent pockets empty)	150 mm
Lunghezza max. utensile		Max. tool length	300 mm
Peso max. utensile		Max. tool weight	14 kg
Tempo medio cambio utensile truciolo - truciolo		Average changing time (chip to chip)	15 sec

Dimensioni e peso

Larghezza x profondità x altezza	Machine dimensions and Weight	Length x width x height	6327 x 4137 x 3748 mm
Peso		Weight	24000 kg

CNC applicabili

Available CNC	Heidenhain iTNC 640 Siemens 840D sl Fanuc 31i MB
----------------------	--



Rema Control s.r.l.

Via Del Carroccio, 102 - 24040 STEZZANO (BG) - Italy
Tel. +39 035 592002 - Fax +39 035 592382
e-mail: marketing@remacontrol.it - www.remacontrol.it

Seguici su



Tipolito Castel - BG - 03/18

ICARO



➤ **Centro di lavoro verticale/orizzontale a montante mobile**
Moving column vertical/horizontal machining center





Ampia area di lavoro con ingombri ridotti e grande visibilità. Possibilità di lavorare particolari a 5 assi in continuo con posizionamento verticale ed orizzontale.

Wide working area with increased visibility and reduced space requirements. The machine allow for the machining of 5 simultaneous axes complex pieces with both vertical and horizontal positioning



Cambio utensile rapido ed espandibile fino a 300 utensili

Fast tool changer with several available choices, until 300 tools.

Testa a uno o 2 assi (opzione) con potenti elettromandri per prestazioni e precisioni elevate.

One or two axes (option) head unit with powerful electrosplindles for high performances and high precisions.

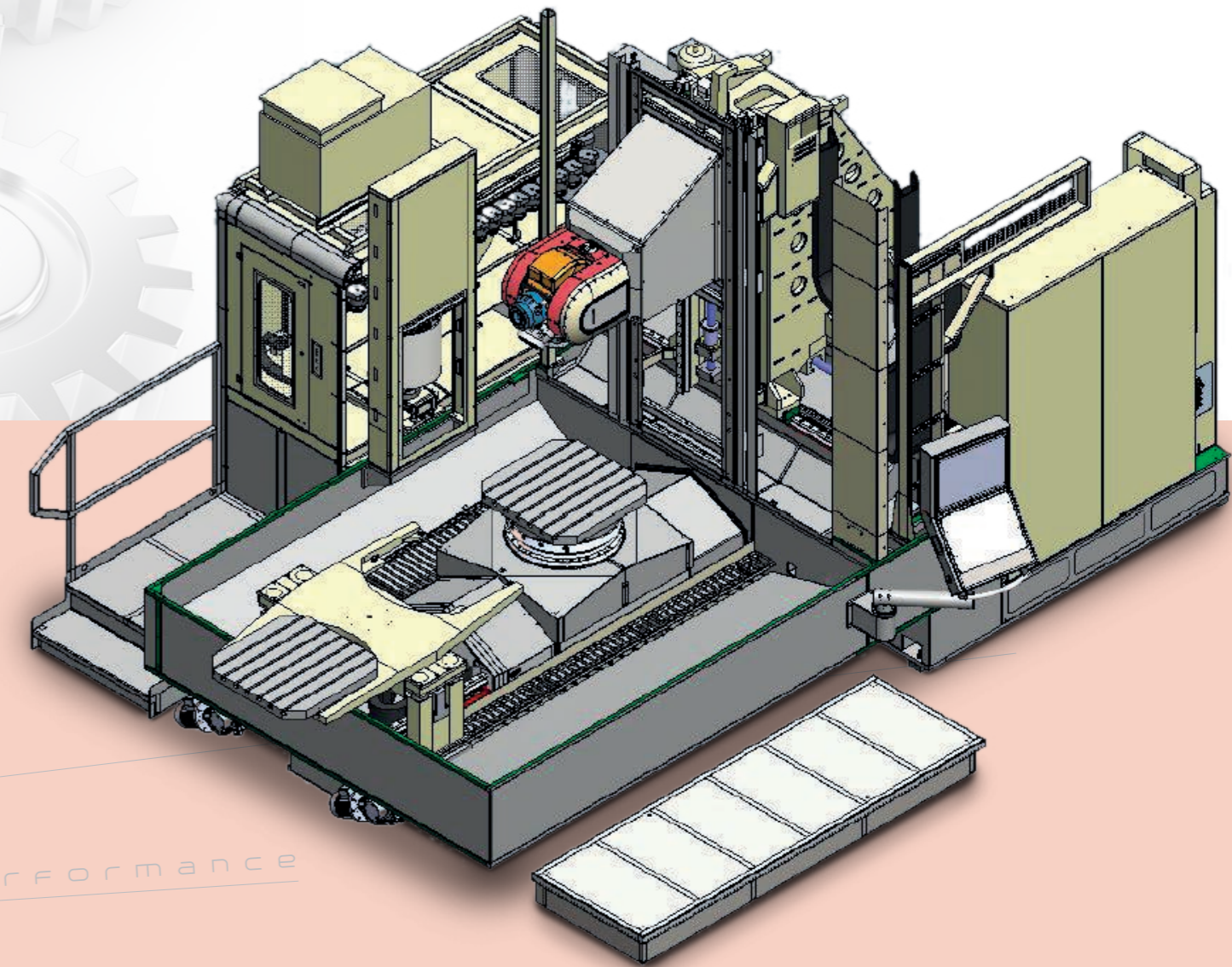

high performance



Disponibile anche con sistema cambio pallet per carico e scarico dei pezzi in tempo mascherato ed elevata produttività.

The machine can be provided also with a pallet changer system that allow for the load and upload of pieces in masked time for increased productivity.

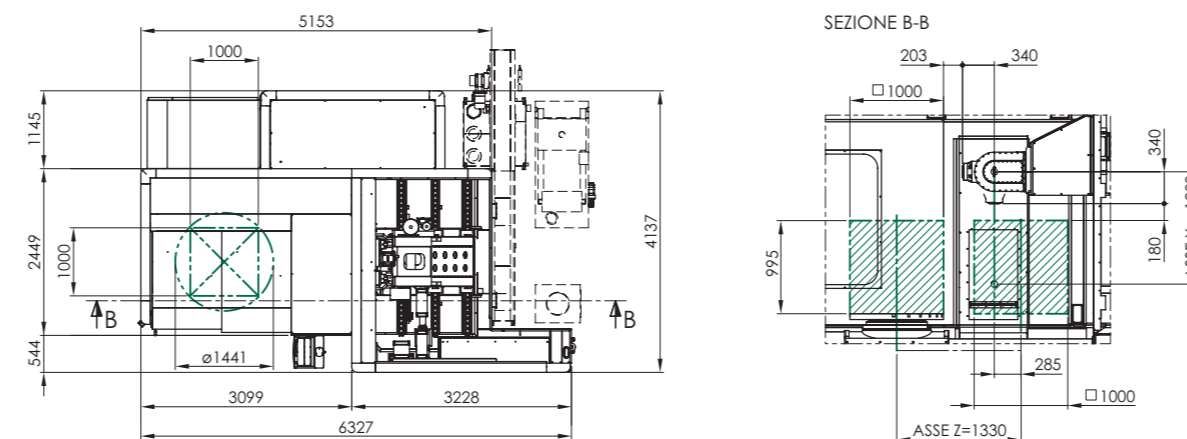

Stabilità e rigidità elevate grazie al basamento monoblocco normalizzato ed alla struttura a tre guide portanti di nuova concezione accuratamente dimensionata.

The correctly dimensioned single-piece bed and the newly designed column structure that lays on 3 guides grant extreme stability and rigidity.

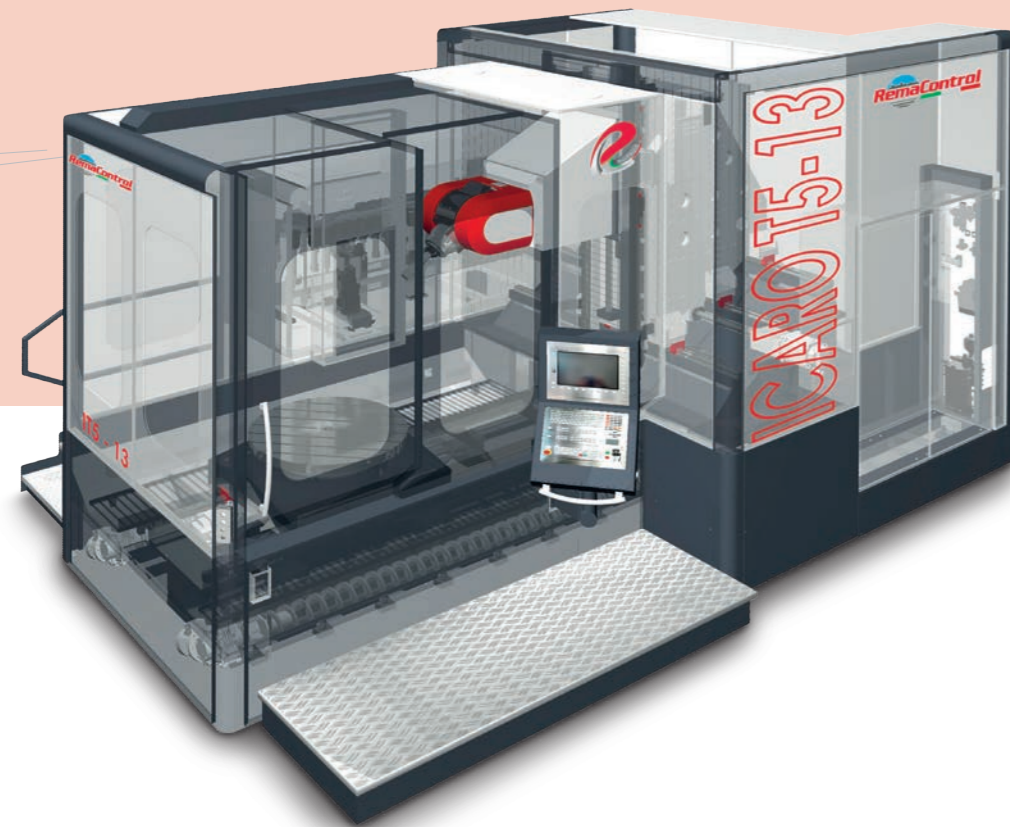

Strutture di nuova concezione attentamente analizzate tramite i più avanzati sistemi CAD e FEM

Newly designed structures carefully analyzed by the most advanced CAD and FEM systems