



2009 TIMTOS Grand Champion Award
 2011 TIMTOS Eminence Award
 2011 TIMTOS Supreme Excellence Award



WELE

GENERAL CATALOG



WELE MECHATRONIC CO., LTD

(<http://www.welegroup.com>)

HEADQUARTERS:

No.458, Shinsing Rd., Hukou Town, Hsin-Chu County 303, Taiwan
 TEL : +886-3-696-0360 (rep.) FAX : +886-3-696-0370

TAICHUNG BRANCH:

No.356, Sanfeng Rd., Houli Dist., Taichung City 421, Taiwan
 TEL : +886-4-2558-0762 FAX : +886-4-2558-2334

WELE MECHATRONIC (SU-ZHOU) CO., LTD.

No. 8, Ma-Qiao Industrial Block, Chang-Shu Economic Development Zone,
 Chang-Shu City, Jiang-Su Province, 215513, China
 TEL : +86-512-5229-7868 FAX : +86-512-5229-7866
 SALES: 150-5141-3969,150-5141-3981



Website



Contact us

1209302 / MacTIS. TEL: 04-24753326

WELE MECHATRONIC CO., LTD

WELE Profile

- Established: 2007 June 11
- Paid-in Capital: NT\$ 630M (US\$19.38M)
- Majoring Investor:
 - JTEKT Co., (40%)
 - Wele Investment Co., Managing Group, Employees (60%)
- President: Mr. Yong-Chang Kuan
- Certification: ISO9001, ISO14001, CE (TUV Rheinland)
- Factory:
 - Hsinchu Head Quater (17,500 m²)
 - Taichung Branch (18,000 m²)
 - Suzhou Factory, China (6,700 m² + 10,000m²)

Mile Stone

2007/06/11	"WELE Mechatronic Co., Ltd" registered by major shareholder, WELE Investment. The president, Mr. Yong-Chang Kuan, also as General Manager with paid-in capital of US\$ 2.8 million by WELE investment Co.
2007/07/03	WELE opened at No.53, Chung-Tai Rd., Chu-Pei city, Hsin-chu county, and registered WELE Logo as 「WELE」
2007/08/23	WELE increased paid-in capital with US\$ 13 million by Wele investment.
2007/10/01	WELE Taichung #1 factory had opening with total 89 employees at No.558-1, Shenhjhou Rd., Shengang town, Taichung county.
2007/10/27	WELE's Head quarter and Hsin-Chu factory had opening with total 103 employees at No.458, Shinsing Rd., Hukou town, Hsin-chu county.
2007/12/01	WELE Taichung #2 factory opened and established at No.206, Sec.1, Guofong Rd., Fong-Yuan Dist., Taichung City.
2008/01/16	WELE's President, Mr. Yong-Chang Kuan and JTEKT President, Mr. Motohiko Yokoyama both signed the cooperation agreement in the JTEKT headquarter in Nagoya, Japan.
2008/01/23	WELE first AA machining centers: AA1165 & AA1365, under TOYODA brand officially exhibited at Global Technical Fair by JTKET in Nagoya, Japan.
2008/01/31	WELE applied for capital increase to US\$ 24 million with paid-in capital US\$ 22 million. WELE investment Co. possess 60% stock ownership (US\$13.4 million) and JTEKT has 40% stock ownership (US\$ 8.6 million).
2009/03/03	UG550 won the Grand Champion Award in Research and Innovation at the category of Machining Center in TIMTOS 2009.
2011/03/02	WELE HB-430F, Horizontal Boring and Milling Machining Center won the Taiwan Machine Tools Industry Award 2011 for "Eminence Award" in Research and Innovation at Category of Machining Center. WELE VTC2500H, Vertical Multi-Tasking Turning Center won the Taiwan Machine Tools Industry Award 2011 for "Supreme Excellence Award" in Research and Innovation at all category.
2011/09/19	WELE firstly join the EMO Hannover 2011 (19th to 24th September 2011) and exhibited the machines RB-312 & UG800 as WELE brand.
2012/10/04	WELE Taichung Branch at CTSP formally established.
2012/12/31	Reached to US\$ 90 million annual turnover.
2013/03/04	WELE Taichung Branch opens at No.356, Sanfeng Rd., Houli Dist., Taichung City.

Message from the President

WELE Mechatronic Co., Ltd. was founded and formed from the initial concepts of "The investors and labors cooperate together." & "Tolerating mutually is the way to grow." We keep our own philosophy to construct the foundation of our long term and continuous operational entrepreneur. WELE local shareholders own 60% share and accepts the rest of 40% share by the JTEKT group (including TOYODA KOKI) who is sub-group of TOYOTA car maker. WELE majority managing team members were derived from Mechanical Industrial Research Laboratory of Industrial technology Research Institute in Taiwan who had been working in the Machine Tool business operation for more than 25-year experience. WELE managing team is well-known in Taiwan machine tool industry of developing big size bridge machine and as the professional machine tool builder with advanced technology. WELE has successfully developed more

than 60 high level models of new products, including big bridge machines working range between 600mm and 16000mm in X direction, 500mm and 6000mm in Y direction with five sides, five axes, high speed machining functions and horizontal boring function. Especially the UG series five axes machining center won the excellent award in the machining center category of 2009 Taiwan Machine Tools development and innovation contest. And again, in the 2011 Taiwan Machine Tools Development and Innovation Contest, our own development: VTC series (Vertical Turning Center) and HB series (Horizontal Boring Machine), won the supreme excellence award and eminence award. When WELE announced those series of "five side family," "five axes family," and "high speed group" of various high level machine tools in the market, we well received and met the demanding diversities from various technology needed industrious customers. We sincerely appreciated you all very much.



WELE insists on our own philosophy with professional managing team achieving our core value to face the varied markets. WELE's excellent ability is to offer our customers the reliable products and innovative technology with rich and experimental service resources. WELE will always be your best partner. Thank you.

Y. C. Kuan

SALES PERFORMANCE SINCE 2008

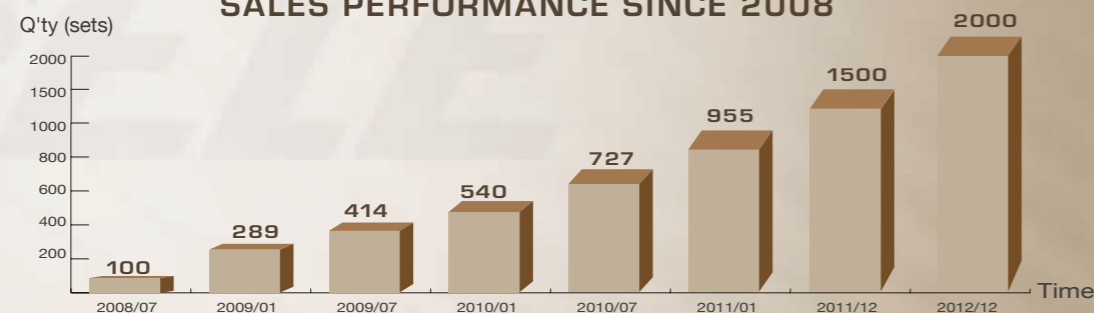

Product Overview

UA90 series



AA90 series



MVB series



AA80 series

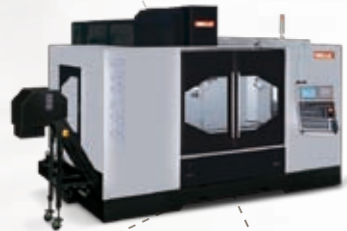

LB series

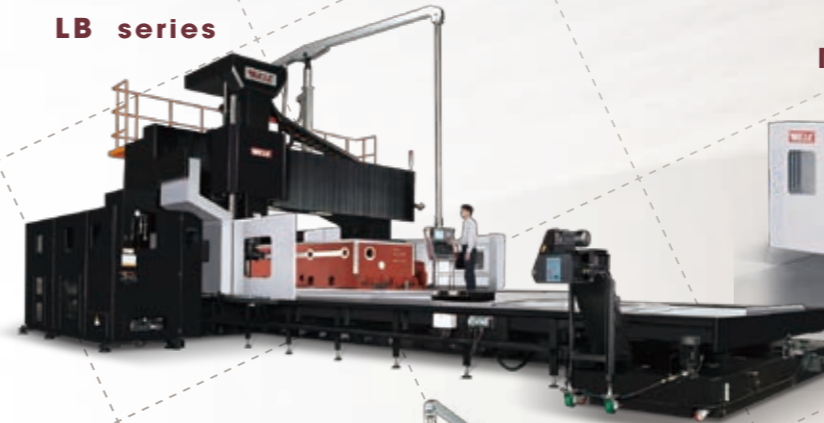

MG/MG-U series



UG series



RB/SB series



UG550
Grand Champion Award in
Innovation Contest TIMTOS 2009



MB series

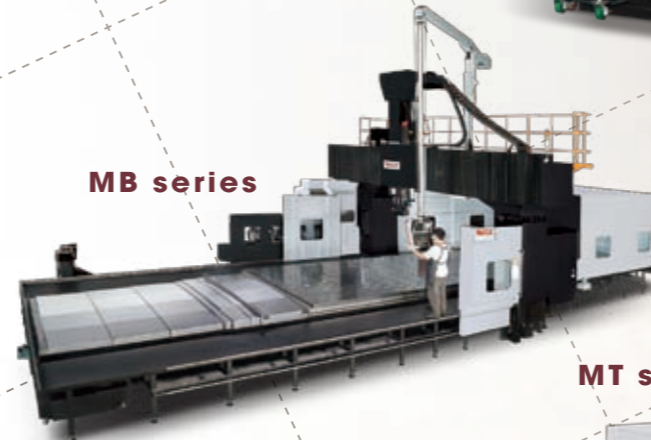

UB series

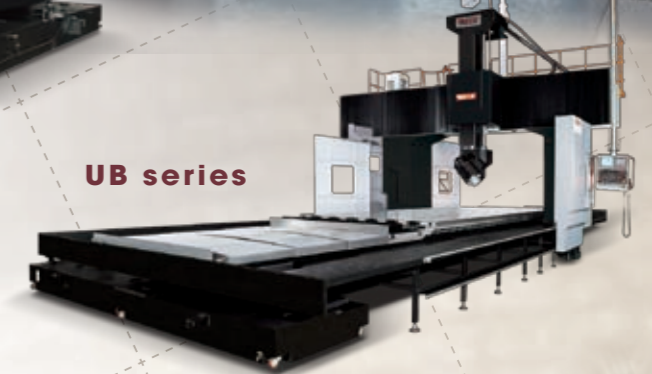

AA65 series

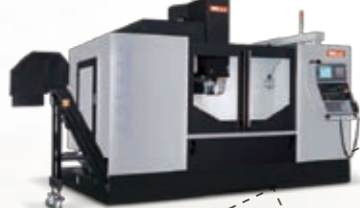

VTC series



MT series



AQ50/65 series

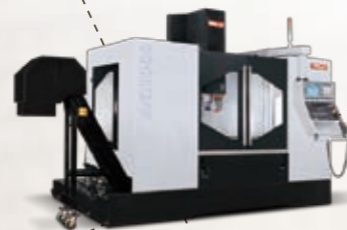

VTC2500
Supreme Excellence Award in
Innovation Contest TIMTOS 2011



HB/HB-F series

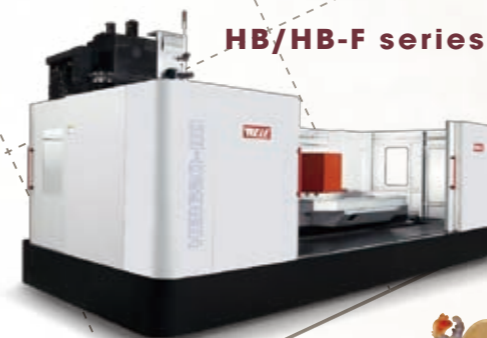

HB430F
Eminence Award in
Innovation Contest of TIMTOS 2011



VQ series



Y axis
5000mm
500mm

X axis
800mm
16000mm

R&D Core Value Advanced Technology, Modular Design



• 13 Patents approval

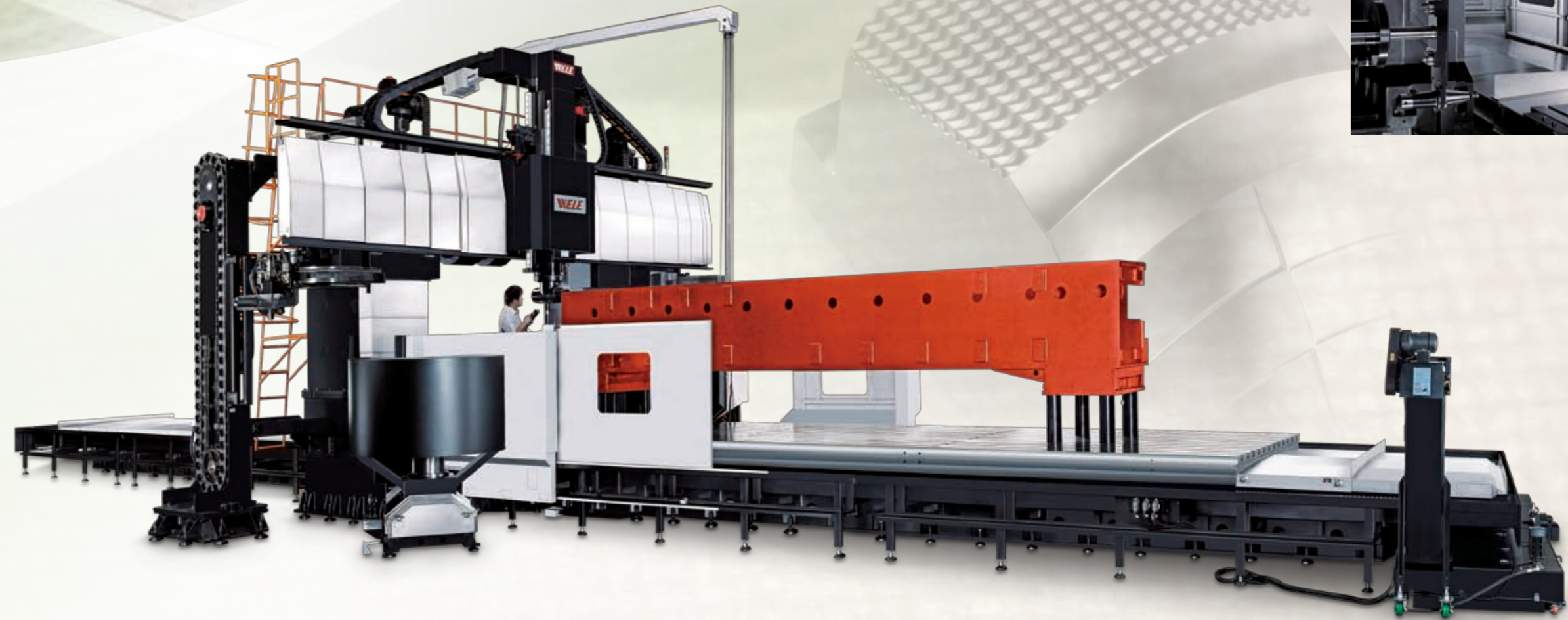
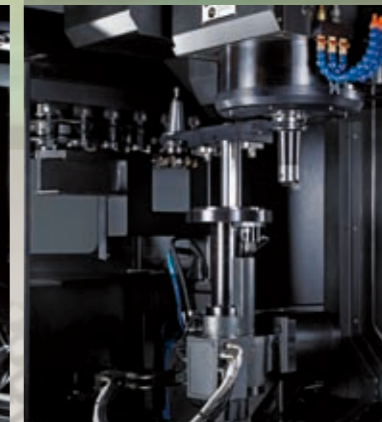

High Skill Manufacturing Technology



Quality Assured Manufacturing Technology



Application

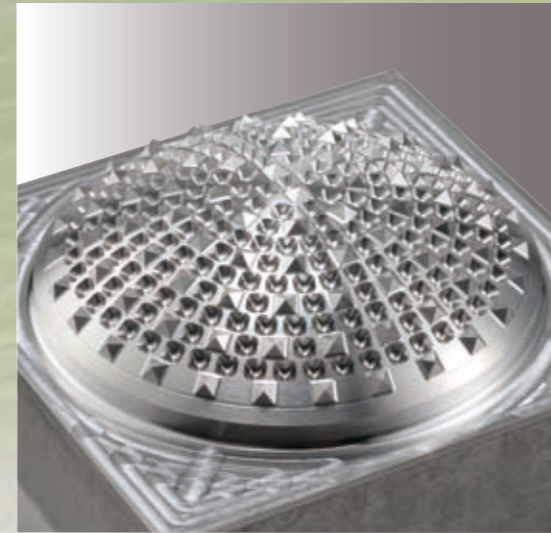

WELE Production Plant



Exhibitions and Promotion



AA65 series



- Developed for general purpose heavy duty metal cutting. Available on #40 and #50 geared spindle.
- Compact design concept: easy to ship in regular container.
- Machine bed, column, carriage, and spindle head are well annealed with aged heat treatment.
- More than 56 surfaces are scraped by skilled technicians to get excellent geometric accuracy.
- 4 Harden ways well arranged on Y axis to be sure the work load full support.

ITEM	UNIT	AA965	AA1165	AA1365	AA1565
X travel (Left & Right)	mm (in)	900 (35.4)	1100 (43.3)	1300 (51.2)	1500 (59.1)
Y travel (In & Out)	mm (in)	650 (25.6)			
Z travel (Up & Down)	mm (in)	600 (23.6)			
Table size (X Direction)	mm (in)	1100 (43.3)	1300 (51.2)	1450 (57.1)	1650 (65)
Table size (Y Direction)	mm (in)	650 (25.6)			
Table load capacity	kg (in)	900 (1984)	1100 (2425)	1300 (2866)	1500 (3307)

AA80 series

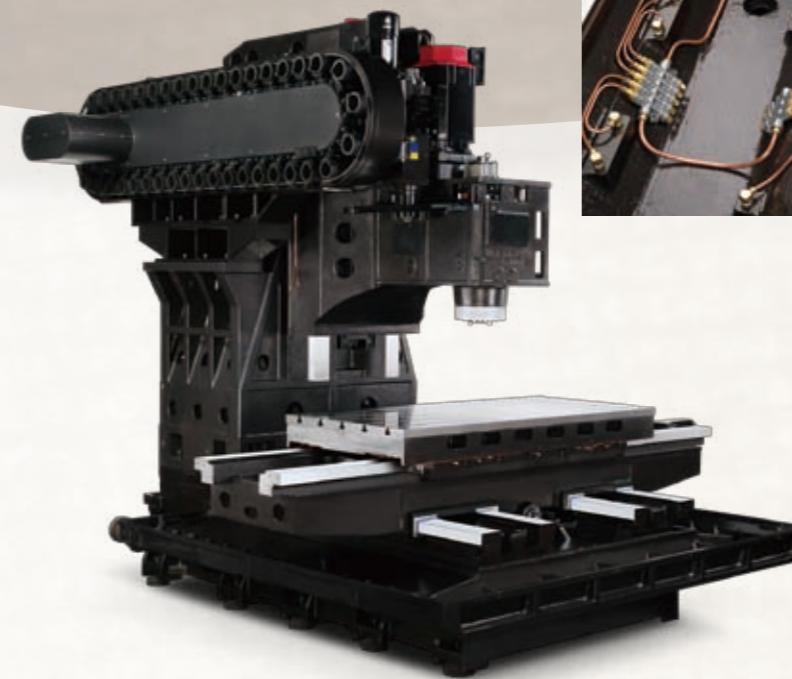

- Developed for general purpose heavy duty metal cutting. Available on #50 geared spindle.
- Machine bed, column, carriage, and spindle head are well annealed with aged heat treatment.
- Y travel 800mm with rigid overhang spindle head stock.
- More than 56 surfaces are scraped by skilled technicians to get excellent geometric accuracy.
- 4 Harden ways well arranged on Y axis to be sure the work load full support.

ITEM	UNIT	AA1480	AA1680	AA1880
X travel (Left & Right)	mm (in)	1400 (55.1)	1600 (63)	1800 (70.9)
Y travel (In & Out)	mm (in)	800 (31.5)		
Z travel (Up & Down)	mm (in)	700 (27.6)		
Table size (X Direction)	mm (in)	1550 (61)	1750 (68.9)	1950 (76.8)
Table size (Y Direction)	mm (in)	800 (31.5)		
Table load capacity	kg (lb)	1800 (3968)	2000 (4409)	2200 (4850)

AQ50/65 series

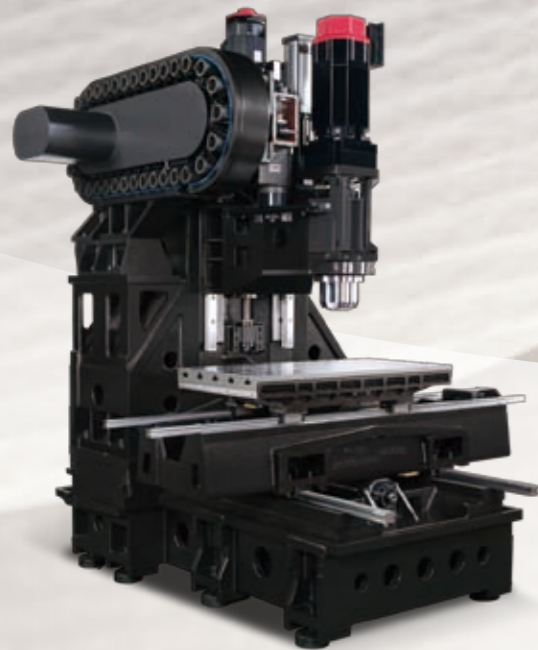

- Developed for high performance axial movement by ball/roller guide way, high response on feed system and higher spindle speed with 10000rpm or more.
- Well arrangement for light alloy material cutting and aluminum application.
- Y axis available to up to 650mm & X axis available to up from 1200mm thru 1600mm.
- 48m/min fast feed movement is to provide high response on this field.



ITEM	UNIT	AQ850	AQ1050	AQ1265	AQ1465	AQ1665
X travel (Left & Right)	mm (in)	800 (31.5)	1020 (40.2)	1200 (47.2)	1400 (55.1)	1600 (63)
Y travel (In & Out)	mm (in)	510 (20.1)		650 (25.6)		
Z travel (Up & Down)	mm (in)	510 (20.1)		610 (24)		
Table size (X Direction)	mm (in)	1000 (39.4)	1200 (47.2)	1400 (55.1)	1600 (63)	1750 (68.9)
Table size (Y Direction)	mm (in)	510 (20.1)		650 (25.6)		
Table load capacity	kg (lb)	500 (1102)	600 (1323)	1000 (2205)	1000 (2205)	1000 (2205)

AA90 series



- Developed for general purpose ultra heavy duty metal cutting. Available on #50 geared spindle.
- Machine bed, column, carriage, and spindle head are well annealed with aged heat treatment.
- More than 62 surfaces are scraped by skilled technicians to get excellent geometric accuracy.
- Twin driven system used on Y axis to provide heavy movement performance.
- 4 Harden ways and 2 roller guide ways well arranged on Y axis with 900mm travel ensure the work load full support [available for AA2590].
- Triple screw type chip conveyor go along with Y axis direction to dispatch the chip from working envelope.

ITEM	UNIT	AA1890	AA2090	AA2590
X travel (Left & Right)	mm (in)	1800 (70.9)	2000 (78.7)	2500 (98.4)
Y travel (In & Out)	mm (in)	900 (35.4)		
Z travel (Up & Down)	mm (in)	900 (35.4)		
Table size (X Direction)	mm (in)	1950 (76.8)	2150 (84.6)	2650 (104.3)
Table size (Y Direction)	mm (in)	900 (35.4)		
Table load capacity	kg (lb)	2000 (4409)	2200 (4850)	3000 (6614)

UA series

FIVE AXES MACHINE

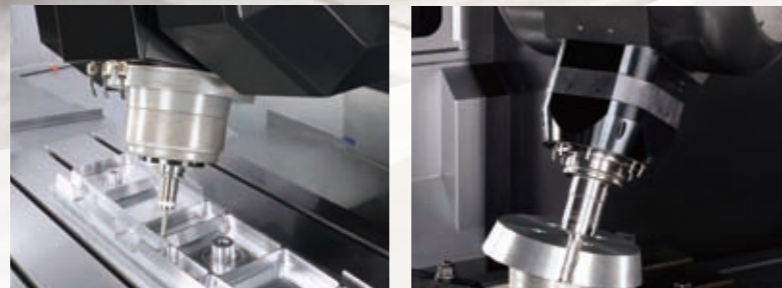
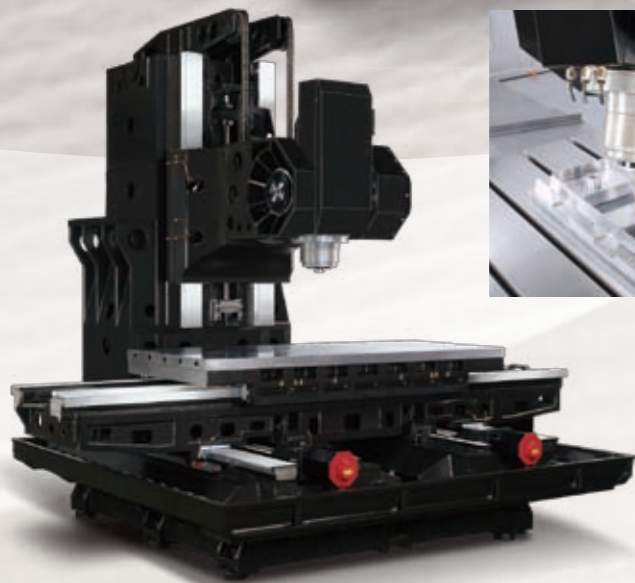
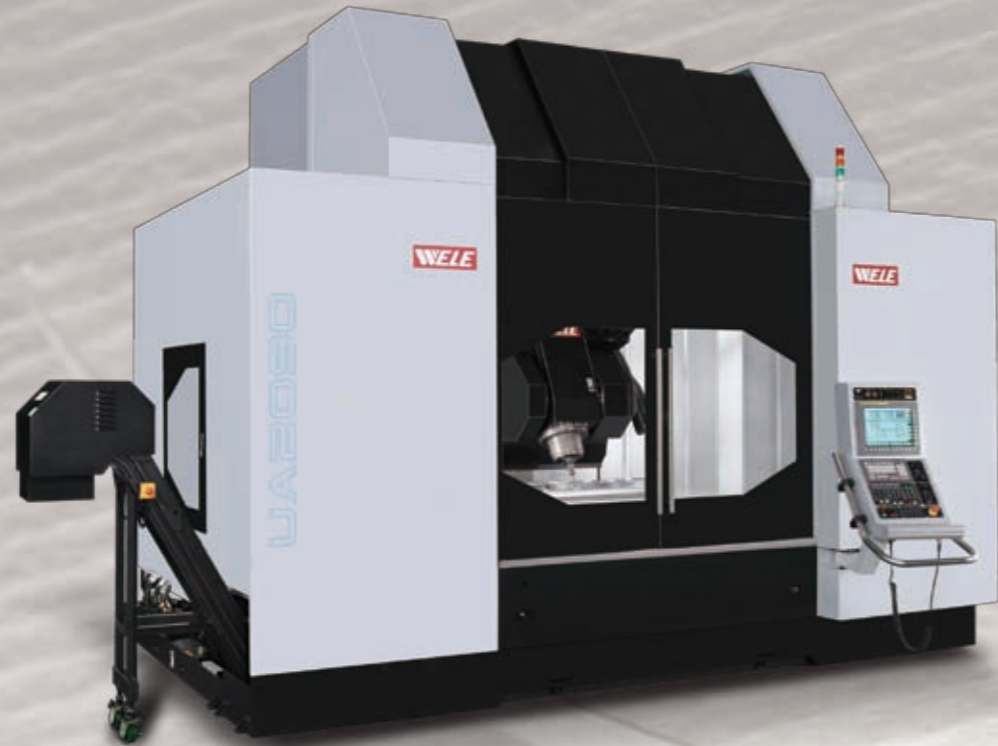

- Robust design for 5 axes simultaneous application jobs for aerospace parts machining.
- High rigid design of AB tilting head with max torques of 4950Nm/3650ft-lb on A axis and 7960Nm/5870ft-lb on B axis.
- Dual driven feed system on Y axis provides heavy movement performance.

ITEM	UNIT	UA2090	UA2590
X travel (Left & Right)	mm (in)	2000 (78.7)	2500 (98.4)
Y travel (In & Out)	mm (in)	900 (35.4)	
Z travel (Up & Down)	mm (in)	900 (35.4)	
A travel (Rotating)		± 30° (BBT50), 40° (BBT40)	
B travel (Tilting)		± 30° (BBT50), 40° (BBT40)	
Clamping area	mm (in)	2150x900 (84.6x35.4)	2650x900 (104.3x35.4)
Table load	Nm (lb)	2200 (4400)	2500 (5500)
Spindle Speed/Torque	rpm (Nm/ft-lb)	8000 (600 / 132.2)	
Spindle Speed/Torque	rpm (Nm/ft-lb)	12000 (420 / 92.5)	

UG series

FIVE AXES MACHINE



- Compact design for 5 sides & 5 axes simultaneous application jobs: Aerospace and general parts machining.
- Overhead moving gantry by twin driving system on Y axis.
- Own developed Trunion AC table provide max torque of 6000Nm on A, 2000Nm on C axis.
- Max. tool capacity of 60 is optional available.
- Heidenhain and FANUC controller both available on this field.



ITEM	UNIT	UG550	UG800
X travel (Left & Right)	mm (in)	550 (21.7)	800 (31.5)
Y travel (In & Out)	mm (in)	700 (27.6)	950 (37.4)
Z travel (Up & Down)	mm (in)	500 (19.7)	650 (25.6)
A travel (Rotation)	degree	+30 / -120	+30 / -120
C travel (Rotation)	degree	360	360
Table diameter	mm (in)	550 (21.7)	800 (31.5)
Table for divide degree	degree	0.001	0.001
Table load capacity	kg (lb)	500 (1102)	1000 (2205)

RB/SB series

MACHINING CENTER

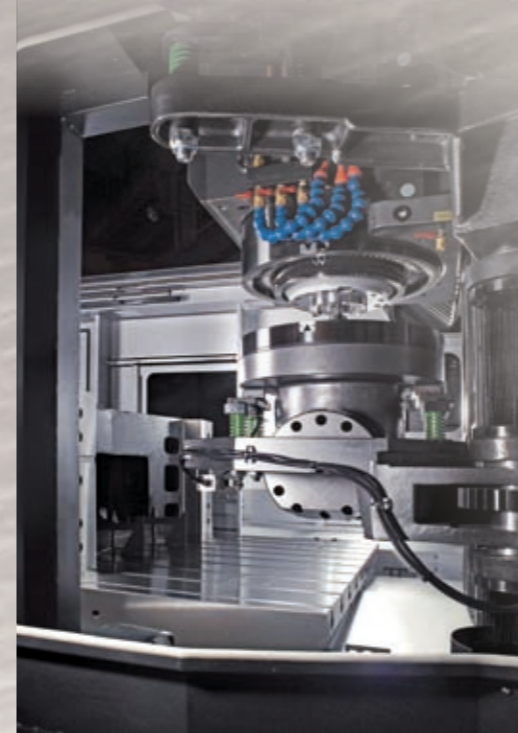

- The most economical equipment for 3 axes machining on this field.
- Economical multi-head exchange & storage with tool exchange function automatically upgrade to 5 sides function optional available on this series.
- 5 sides work coordinate plane convert system auto attach with this optional function.
- Bridge casting made in one piece.

- Developed for high precision, heavy duty, and high performance on the smallest bridge range.
- All axes are using ultra-heavy roller guideway.
- Super wide operator door (full open). Easy to load and unload the workpiece.
- Max. rapid feed up to 24m/min.

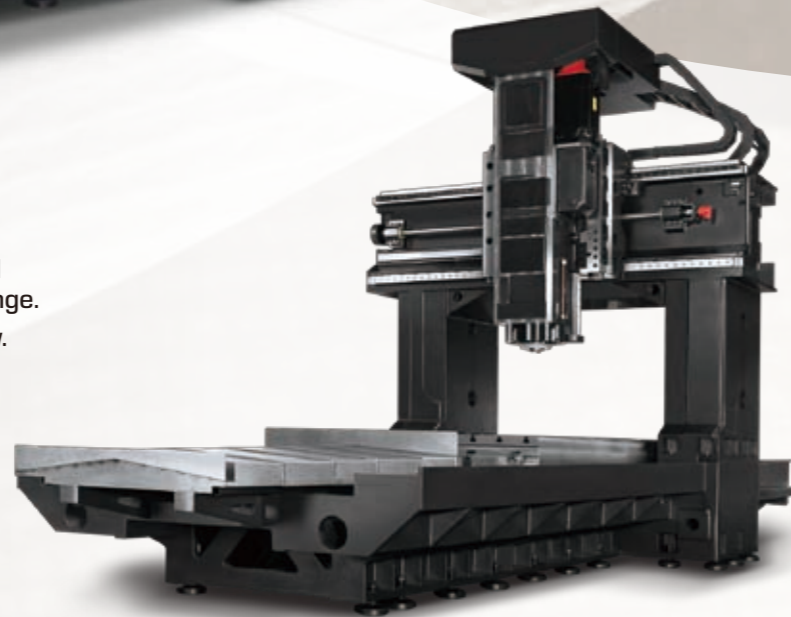

ITEM	UNIT	RB212	RB312	SB216(Y)	SB316(Y)	SB416(Y)
X travel (Left & Right)	mm (in)	2120 (83.5)	3060 (120.4)	2120 (83.5)	3060 (120.4)	4060 (159.8)
Y travel (In & Out)	mm (in)	1200 (47.2)		1600 (62.9) / 2300 (90.5)		
Z travel (Up & Down)	mm (in)	800 (31.4)		800 (31.4 as standard, 1000(39.4) as optional)		
Table size (X Direction)	mm (in)	2000 (78.7)	3000 (118.1)	2000 (78.7)	3000 (118.1)	4000 (157.4)
Table size (Y Direction)	mm (in)	1100 (43.3)		1500 (59.0)		
Table load capacity	kg (lb)	3500 (7716)	4500 (9921)	8000 (17637)	10000 (22046)	12000 (26455)

LB series

MACHINING CENTER



- The most economical equipment for 3 axes machining on this field.
- Economical multi-head exchange & storage with tool exchange function automatically upgraded to 5 sides function on this field.
- 5 side work coordinate plane convert system auto attached with this optional function as M type. Named as LB__M.
- Z travel with 800mm as STD; 1000mm, 1200mm & 1400mm available as an option.
- X travel can be provided up to 10 meter as required.

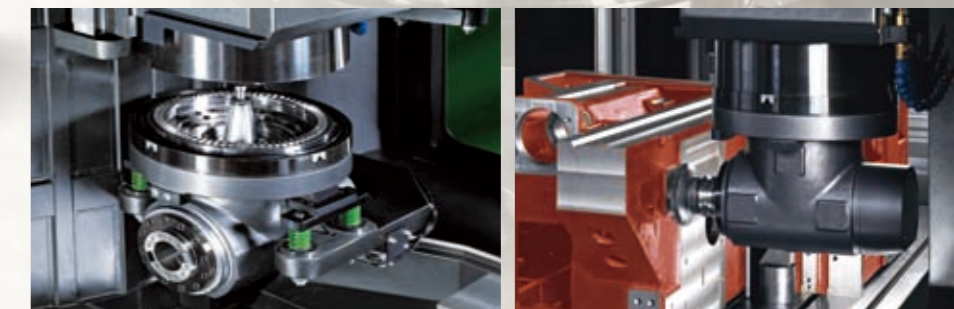

ITEM	UNIT	LB321(Y)	LB421(Y)	LB521(Y)	LB325(Y)	LB425(Y)	LB525(Y)	LB625(Y)	LB533(Y)	LB633(Y)
X travel (Left & Right)	mm (in)	3060 (120.4)	4060 (159.8)	5060 (199.2)	3060 (120.4)	4060 (159.8)	5060 (199.2)	6060 (238.5)	5060 (199.2)	6060 (238.5)
Y travel (In & Out)	mm (in)	2150 (84.6) / 2800 (110.2)			2550 (110.3) / 3250 (127.9)			3300 (129.9) / 4000 (157.4)		
Z travel (Up & Down)	mm (in)	800 (31.4) as Standard, 1000 (39.3), 1200 (47.2), 1400 (55.1) as Optional				800 (31.4) as Standard, 1000 (39.3), 1200 (47.2), 1400 (55.1) as Optional				
Table size (X Direction)	mm (in)	3000 (118.1)	4000 (157.4)	5000 (196.8)	3000 (118.1)	4000 (157.4)	5000 (196.8)	6000 (236.2)	5000 (196.8)	6000 (236.2)
Table size (Y Direction)	mm (in)	2000 (78.7) / 2400 (94.5)			2400 (78.7) / 2500 (98.4)			2400 (78.7) / 2500 (98.4)		
Table load capacity	kg (lb)	12000 (26455)	15000 (33069)	18000 (39683)	12000 (26455)	15000 (33069)	18000 (39683)	20000 (44092)	20000 (44092)	22000 (48500)

MB series

FIVE SIDES MACHINING CENTER



- Full automatic Head Exchange/ Head Storage/ Auto tool exchange in vertical & horizontal/ 5 sides machining function.
- Z travel with 1000mm as STD; Z travel from 1200mm thru 1400mm available on all MB series.
- Automatic multi head exchange system and storage with tool exchange in vertical and horizontal.
- All series with linear scale feedback system on X, Y axes; Z axis (OPT).
- Extension head, 30 degree head, and universal head optional available.



ITEM	UNIT	MB425	MB525	MB625	MB725	MB432	MB532	MB632	MB732
X travel (Left & Right)	mm (in)	4060 (159.8)	5060 (199.2)	6060 (238.6)	7060 (278)	4060 (159.8)	5060 (199.2)	6060 (238.6)	7060 (278)
Y travel (In & Out)	mm (in)	3200 (126)				3900 (153.5)			
Z travel (Up & Down)	mm (in)	1000 (39.4)				1000 (39.4)			
Table size (X Direction)	mm (in)	4000 (157.5)	5000 (196.9)	6000 (236.2)	6000 (236.2)	4000 (157.5)	5000 (196.9)	6000 (236.2)	6000 (236.2)
Table size (Y Direction)	mm (in)	2000 (78.7)				2400 (94.5)			
Table load capacity	kg (lb)	15000 (33069)	18000 (39683)	20000 (44092)	20000 (44092)	15000 (33069)	18000 (39683)	20000 (44092)	20000 (44092)

UB series

FIVE AXES MACHINE



- An additional tilting head available on all sizes of LB series machines called as UB series five axes simultaneous bridge machines.
- Own design or purchased tilting head are all available as required.
- Tilting angle range of $\pm 110^\circ$ on A axis and $\pm 360^\circ$ on C axis.
- Z axis travel in 800mm as STD, 1000mm, 1200mm & 1400mm available as options.
- The UB machine is mainly for European and US markets.
- Equipping with FANUC/HEIDENHAIN controllers are available in tilting head made in Germany.



ITEM	UNIT	UB421Z	UB425YZ2
X travel (Left & Right)	mm (in)	4060 (159.8)	4060 (159.8)
Y travel (In & Out)	mm (in)	2150 (84.6)	3200 (126.0)
Z travel (Up & Down)	mm (in)	1000 (39.4)	1200 (42.4)
A travel (Rotation)	degree	± 110	± 110
C travel (Rotation)	degree	± 360	± 360
Table size (X Direction)	mm (in)	4000 (157.5)	4000 (157.5)
Table size (Y Direction)	mm (in)	2000 (78.7)	2400 (94.5)
Table load capacity	kg (lb)	15000 (33000)	15000 (33000)

MVB series

CROSS RAIL UP & DOWN FIVE SIDES MACHINE

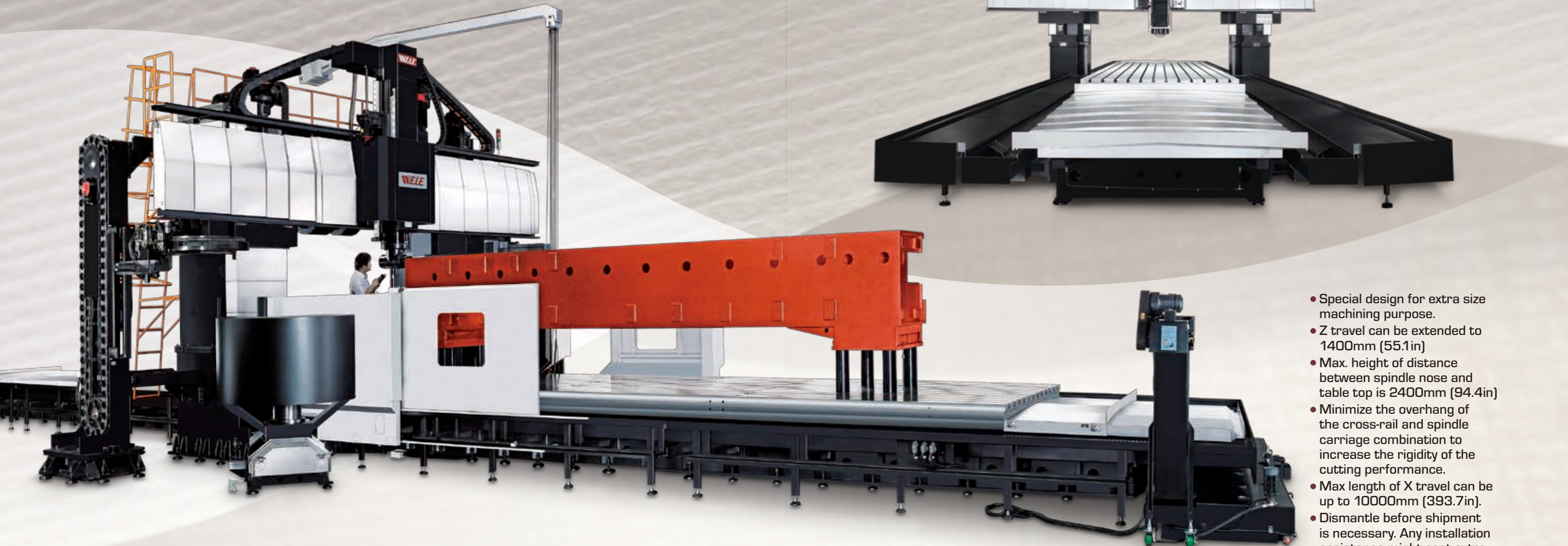

- Special design for extra size machining purpose.
- Z travel can be extended to 1400mm (55.1in)
- Max. height of distance between spindle nose and table top is 2400mm (94.4in)
- Minimize the overhang of the cross-rail and spindle carriage combination to increase the rigidity of the cutting performance.
- Max length of X travel can be up to 10000mm (393.7in).
- Dismantle before shipment is necessary. Any installation assistance might cost extra.

ITEM	UNIT	MVB 532	MVB632	MVB832	MVB539	MVB639	MVB839	MVB1039
X travel (Left & Right)	mm (in)	5060 (199.2)	6060 (238.5)	8060 (317.3)	5060 (199.2)	6060 (238.5)	8060 (317.3)	10060 (396.1)
Y travel (Carriage Forward & Reverse)	mm (in)	3200 (125.9)	3200 (125.9)	3200 (125.9)	3900 (153.5)	3900 (153.5)	3900 (153.5)	3900 (153.5)
Z travel (Spindle Up & Down)	mm (in)		1000 (39.4)			1000 (39.4)		
W travel (Cross Rail Up & Down)	mm (in)		1200 (47.2)			1200 (47.2)		
Between columns	mm (in)		2600 (102.3)			3300 (129.9)		
Distance between spindle & table	mm (in)		200~2400 (7.87~94.48)			200~2400 (7.87~94.48)		
Table size (X x Y Direction)	mm (in)	5000x2000 (196.8x78.7)	6000x2000 (236.2x78.7)	8000x2000 (314.9x78.7)	5000 x 2400 (196.8 x 94.4)	6000 x 2400 (236.2 x 94.4)	8000 x 2400 (314.9 x 94.4)	10000 x 2400 (393.7 x 94.4)
Spindle Speed (Geared)	rpm		6000			6000		

MG/MG-U series

MOVING OVERHEAD BRIDGE MACHINE

- Moving overhead gantry bridge machine with max up to 20m in X axis and 5m in Y axis is available.
- Twin driven feed system on X axis travel up to 6000mm with ball screw; rack and pinion driven feed system available with travel 6000mm above.
- Automatic multi-head exchange and storage system, AC tilting head with 5 axes simultaneous control are all optional available on the field.
- Max. table load of 2500kg/m² is provided.
- Special foundation at the customer site is required.
- Patented backlash eliminated mechanism is applied on the X axis travel.

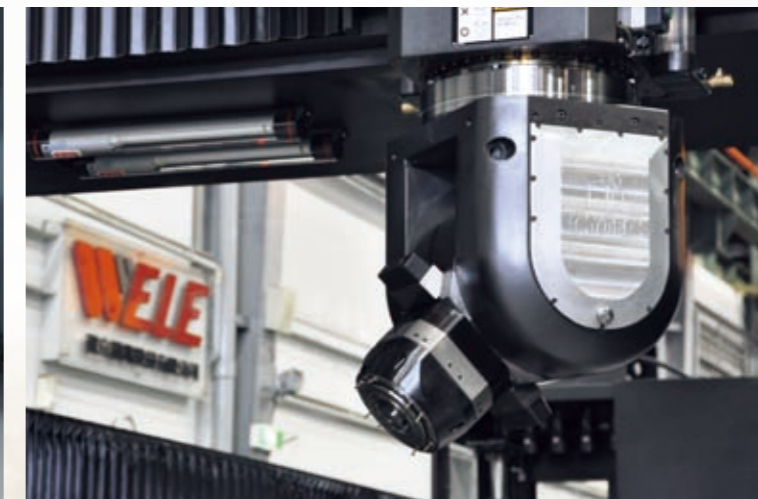
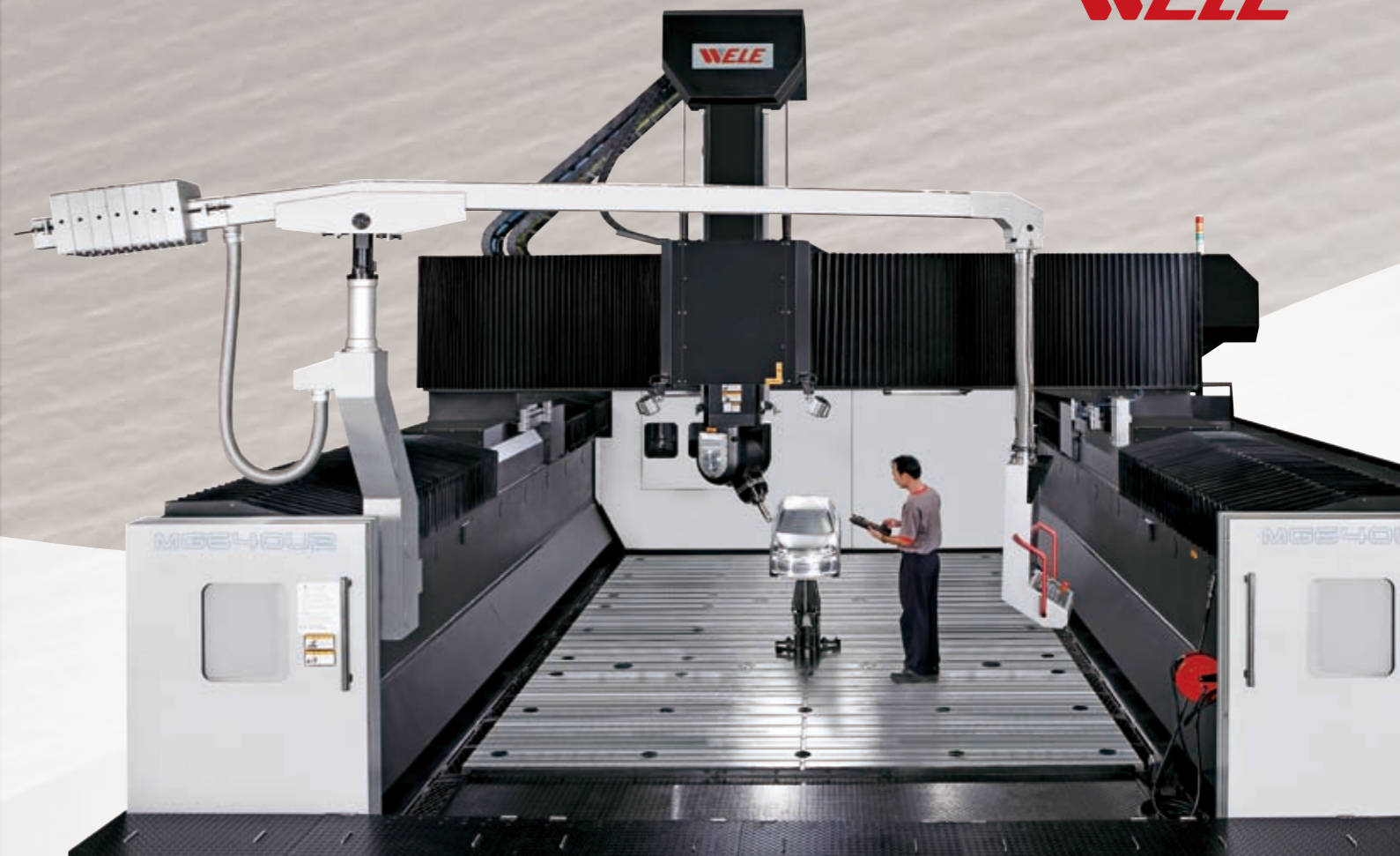

• FANUC/HENDENHAIN controllers are available in tilting head made in Germany. (MG-U series).

ITEM	UNIT	MG530	MG630	MG830	MG1030	MG640	MG840	MG1040	MG650	MG850	MG1050	MG1250	MG1450	MG1650	
X travel (In & Out)	mm (in)	5000 (196.9)	6000 (236.2)	8000 (314.9)	10000 (393.7)	6000 (236.2)	8000 (314.9)	10000 (393.7)	6000 (236.2)	8000 (314.9)	10000 (393.7)	12000 (472.4)	14000 (551.1)	16000 (629.9)	
Y travel (Left & Right)	mm (in)	3000 (118.1)					4000 (157.4)					5000 (196.8)			
Z travel (Up & Down)	mm (in)	1000 (39.3) as standard,						1200 (47.2), 1400 (55.1) as optional							
Table size (X Direction)	mm (in)	5000 (196.9)	6000 (236.2)	8000 (314.9)	10000 (393.7)	6000 (236.2)	8000 (314.9)	10000 (393.7)	6000 (236.2)	8000 (314.9)	10000 (393.7)	12000 (472.4)	14000 (551.1)	16000 (629.9)	
Table size (Y Direction)	mm (in)	2800 (110.2)					3800 (149.6)					4800 (188.9)			
Table load capacity	kg (lb) /m ²	2500 (5512)					2500 (5512)					2500(5512)			

HB/HB-F series

HORIZONTAL BORING MILLING MACHINE

- Two kinds of spindle, Ø110mm (W travel with 500mm) and Ø130mm (W travel with 700mm) Quill type and Ram type combined with Quill travel, provides all kinds of applications.
- Specified Hydro-static bearing offered heaviest loaded on the index table.
- 4000rpm geared spindle with 1,076Nm/793ft-lb offered as STD, 8000rpm built-in spindle with 600Nm/442ft-lb as Option.
- Patented backlash eliminated mechanism gives index table backlash free on the table smaller than 1600x2000mm, two servo motors convert on the table bigger than 2200x2500mm.

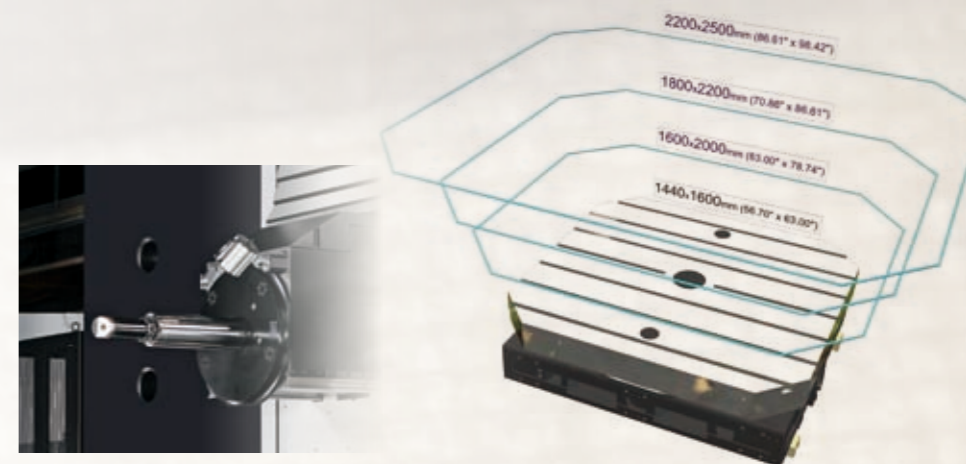

ITEM	UNIT	HB1416-110	HB1620-130	HB430-F	HB430-F	HB535-F	HB535-F
X travel (Left & Right)	mm (in)	2000 (78.7)	3000 (118.1)	4000 (157.4)	4000 (157.4)	5000 (196.8)	5000 (196.8)
Y travel (Up & Down)	mm (in)	1800 (70.8)	2100 (82.6)	3000 (118.1)	3000 (118.1)	3500 (137.7)	3500 (137.7)
Z travel (In & Out)	mm (in)	1300 (51.2)	1500 (59.1)	1500 (59.1)	1500 (59.1)	1500 (59.1)	1500 (59.1)
W travel (Quill or Ram In & Out)	mm (in)	500 (19.6)	700 (27.5)	800 (31.4)	800 (31.4)	800 (31.4)	800 (31.4)
B travel (Rotation)	degree	360	360	360 (OPT)	360 (OPT)	360 (OPT)	360 (OPT)
Distance btwn spindle & table edge	mm (in)	200~2000 (7.8~78.7)	80~2280 (3.1~89.7)	400 (15.7)	400 (15.7)	150 (5.9)	150 (5.9)
Distance btwn spindle & table center	mm (in)	0~1800 (0~70.8)	0~2100 (0~82.6)	700 (27.5)	700 (27.5)	450 (17.7)	450 (17.7)
Table size (X Direction)	mm (in)	1440 (56.7)	1600 (63)	2200 (86.6)	2200 (86.6)	2200 (86.6)	2200 (86.6)
Table size (Y Direction)	mm (in)	1600 (63)	2000 (78.7)	2500 (98.4)	2500 (98.4)	2500 (98.4)	2500 (98.4)
Table load capacity	kg (lb)	8000 (17637)	12000 (26455)	18000 (39683)	12000 (26455)	15000 (33069)	18000 (39683)

VTC series

VERTICAL TURNING & MILLING CENTER

- Vertical Turning center equipped with three-axis control (X, Y, Z) and table indexing enable mechanism.
- Robust machine bed, double column, 260 to 320mm square ram, and curvic coupling tool adaptor for high rigidity.
- With the B-axis indexable rotation table, the single machine can functional as a vertical turning, vertical, horizontal machining center and light grinding purpose. One setup can finish whole process.
- Own developed hydro-static bearing offered heaviest loaded on the rotating table.
- Rotating table equipped with geared driven which provided 139766Nm/103086ft-lb (max.) torque at Ø4000mm table.
- Patented ATC storage can be assigned randomly as quantity needed such as angular head, grinding head, turning tool and vertical tools combination which we named "Puzzle ATC storage".
- Heavy-duty angular head enables five-sides machining with high rigidity.



Specification	Unit	VTC1612-20	VTC-1616-20	VTC2016-24	VTC2020-24	VTC2520-30	VTC2525-30	VTC3025-35	VTC3032-35	VTC4032-48
Turning table diameter	mm(in)	1600 (62.99)			2000 (78.74)		2500 (98.43)		3000 (118.11)	4000 (157.48)
Max. turning height capacity	mm(in)	1200 (47.24)			1600 (62.99)		2000 (78.74)		2500 (98.43)	3200 (125.98)
Max. swing diameter	mm(in)	2000 (78.74)			2400 (94.49)		3000 (118.11)		3500 (137.8)	4800 (188.98)
Distance from table to ram's surface	mm(in)	1400 (55.12)	1800 (70.87)	1800 (70.87)	2200 (86.61)	2200 (86.61)	2700 (106.3)	2700 (106.3)	3400 (133.86)	3400 (133.86)
X axis travel	mm(in)	-810 to 1180 (-31.89 to 46.46)		-1010 to 1380 (-39.76 to 54.33)		-1260 to 1680 (-49.61 to 66.14)		-1510 to 2000 (-59.45 to 78.74)		-2410 to 2600 (-94.88 to 102.36)
Z axis travel	mm(in)	1050 (41.34)	1050 (41.34)	1050 (41.34)	1250 (49.21)	1250 (49.21)	1500 (59.06)	1500 (59.06)	2500 (98.43)	2500 (98.43)
W axis travel	mm(in)	800 (31.5)	1100 (43.31)	1200 (47.24)	1500 (59.06)	1500 (59.06)	1900 (74.8)	1900 (74.8)	2500 (98.43)	2500 (98.43)

MT series

MULTI-MILLING & TURNING

BRIDGE MACHINE

- Multi-task purpose provides various applications and demands : 5 sides milling and turning machining purposes for customers.
- MT series of all in one design concept offers multiple machining procedures: milling, turning, boring, and drilling etc.
- WELE own developed hydro-static bearing of rotary table unit provides the heavy loading and keep long term precise accuracy.
- The rotary table's Cs axis backlash eliminated design reaches indexing in 0.001 degree incrementally.
- Automatic head/ tools exchange system well prepared for milling & turning purposes.

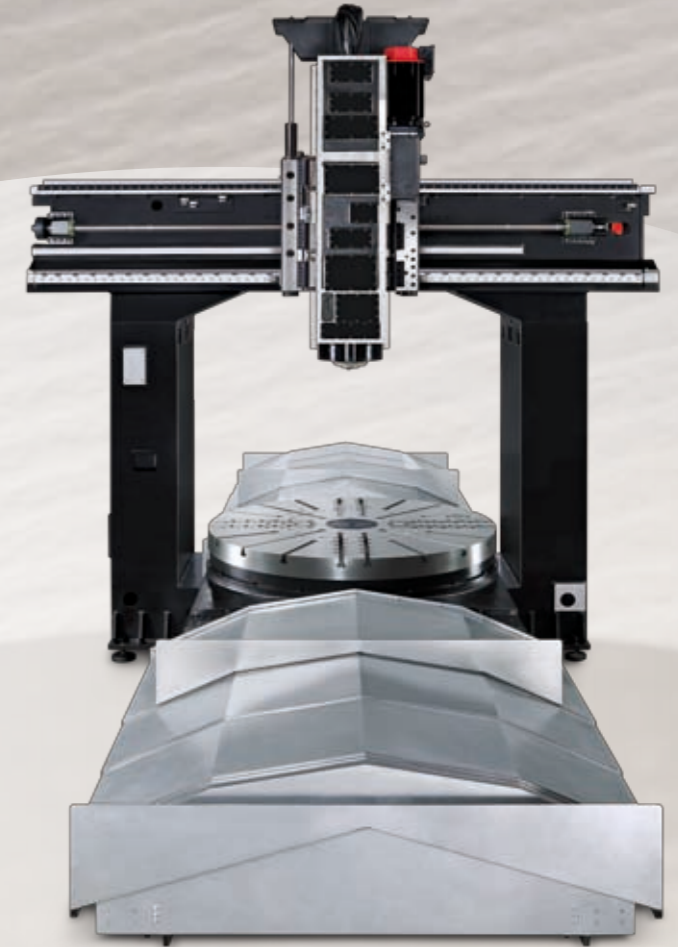

Specification	Unit	MT-16	MT-20
X axis travel	mm(in)	2800 (110.2)	3200 (126.0)
Y axis travel	mm(in)	2600 (102.4)	3000 (118.1)
Z axis travel	mm(in)		800 (31.5)
Turning diameter	mm(in)	1600 (63.0)	2000 (78.7)
Max. turning height	mm(in)		700 (27.6)
Max. swing diameter	mm(in)	2100 (82.7)	2500 (98.4)



• Automatic head exchange system in vertical/horizontal/ turning head.



• Automatic tool exchange system in vertical/horizontal/ turning tool.